

GENERAL NOTES

1. Do not scale, dimension govern.
 2. All dimensions are in millimeters unless noted otherwise.
 3. All dimensions must be checked on site before construction.
 4. Architect should be in written notified of any disagreement.
- All measure and quantity indications on this plan must be checked by the respective contractor before execution; any discrepancies in the documents, tolerance, deviation or other disagreement of any kind must be clarified **In writing** with the architect, the local contractor, and construction management.
- This plan is valid only in conjunction with the text for invitation of tenders including all preliminary remarks, structural engineering plans, domestic technique plans, and expert reports.
- Only the indications of measurements in the plans are binding.
- The British Standard (BS), legal and technical local prescriptions at the time of execution are effective.
- The fasteners shown in the details are not to scale. The necessary strength category and the materials' quality category of all the fasteners must be evaluated by the executing contractor according to the respective static requirements.

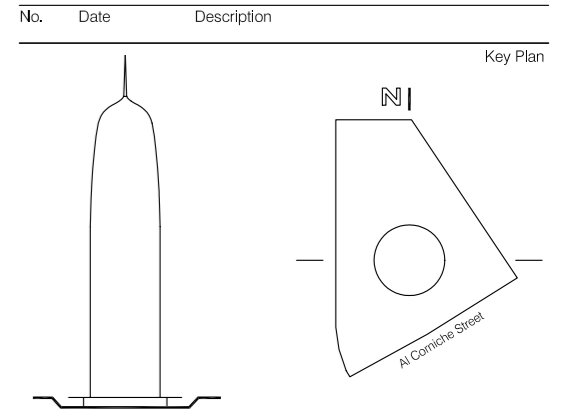
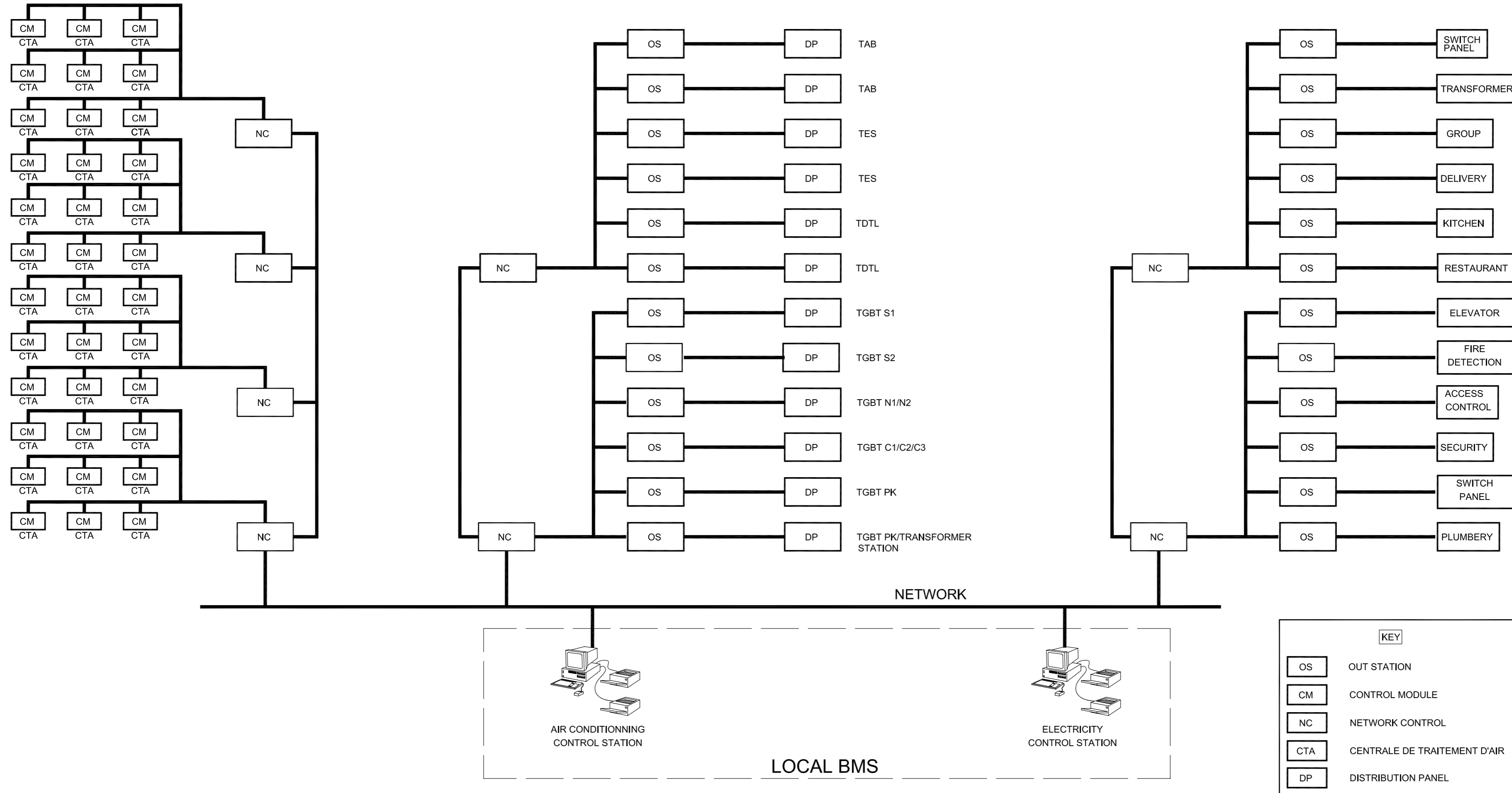

- H.E. Sheikh Saud Al -Thani**
 Client
 P.O. Box 7883 Doha, Qatar
 Tel: +974 485 9705 Fax: +974 436 1531
- ATELIERS JEAN NOUVEL**
 Architect
 10, Cité d'Angoulême 75011 Paris, France
 Tel: +33 (0) 1 49 23 93 93 Fax: +33 (0) 1 43 14 81 10
- TERRELL INTERNATIONAL**
 Structural and M&E Consultant
 11, rue Heinrich 92772 Boulogne-Billancourt cedex, France
 Tel: +33 (0) 1 46 21 07 46 Fax: +33 (0) 1 46 21 03 48
- ARAB ENGINEERING BUREAU**
 Local Architect
 Post Box 1148, Doha, Qatar
 Tel: +974 477 969 Fax: +974 477 888
- BCS S.A.**
 Facade Consultant
 Rue Prieur 1, 2036 Cormondrèche, Switzerland
 Tel: +41 32 732 98 00 Fax: +41 32 732 98 01
- SOCOTEC INTERNATIONAL**
 Security Consultant
 1, avenue du Parc, 78180 Montigny-Le-Bretonneux, France
 Tel: +33 (0) 1 30 12 85 00 Fax: +33 (0) 1 30 12 86 70
- EUROPTIMA**
 Quantities Surveyor
 8, rue Bayen, 75017 Paris, France
 Tel: +33 (0) 1 44 29 27 30 Fax: +33 (0) 1 44 29 27 31
- AVEL ACOUSTIQUE**
 Acoustics Consultant
 43, rue des Moulins des Prés 75013 Paris, France
 Tel: +33 (0) 1 45 88 89 92 Fax: +33 (0) 1 45 88 90 38
- HARDY Ingénieurs et Paysages**
 Landscape Consultant
 3, avenue de Saint Cloud 78000 Versailles, France
 Tel: +33 (0) 1 39 50 50 58 Fax: +33 (0) 1 30 21 42 51
- J.-P. MOLE S.A.**
 Parking Consultant
 8, rue Denis Poisson 75017 Paris, France
 Tel: +33 (0) 1 56 68 00 90 Fax: +33 (0) 1 56 68 03 20
- PLURICONSULT**
 Kitchen Consultant
 4, avenue de la Mairie, 94260 Fresnes, France
 Tel: +33 (0) 1 46 66 47 19
- M T C SURVEYS**
 Surveyor
 P.O. Box 22103 Doha, Qatar
 Tel: +974 4654414 Fax: +974 4654405

High Rise Office Building DOHA - STATE OF QATAR

DETAIL DESIGN
 PRODUCTION INFORMATION / BILLS OF QUANTITIES

LOW CURRENT BMS DIAGRAM

541	LC 004	31.05.2003	-
Job	Cad.ref.	Date	Revision
A2	Scale	FFL +	LC 004
Format	Level / Zone	Level / Zone	Sheet